

xylem
Let's Solve Water

TECHNICAL BROCHURE

BVTXSERIES R1



VTX Series

SUBMERSIBLE SEWAGE PUMP

FEATURES

Impeller: Cast iron, multivane, vortex style

Casing: Cast iron volute for maximum efficiency. Designed for easy installation on A10-20 slide rail or base elbow rail systems.

Mechanical Seal: SILICON CARBIDE VS. SILICON CARBIDE sealing faces for superior abrasive resistance, stainless steel metal parts, BUNA-N elastomers.

Shaft: Corrosion-resistant, 300 series stainless steel. Threaded design. Locknut on all models to guard against component damage on accidental reverse rotation.

Fasteners: 300 series stainless steel.

Capable of running dry without damage to components.

Designed for continuous operation when fully submerged.

EXTENDED WARRANTY AVAILABLE FOR RESIDENTIAL APPLICATIONS.

APPLICATIONS

Specifically designed for the following uses:

- Homes
- Sewage systems
- Dewatering/Effluent
- Water transfer
- Light industrial
- Commercial applications

Anywhere waste or drainage must be disposed of quickly, quietly and efficiently.

SPECIFICATIONS

Pump

- Solids handling capabilities: 2" maximum
- Capacities: up to 208 GPM
- Total heads: up to 66 feet TDH
- Discharge size: 2" NPT threaded as standard.
- Temperature: 104°F (40°C) continuous
140°F (60°C) intermittent.

MOTORS

- Fully submerged in high grade turbine oil for lubrication and efficient heat transfer. All ratings are within the working limits of the motor.

Class B insulation on ½, 1, 1½, 2 HP models.

Single phase (60 Hz):

- PSC motors for improved reliability with no starting switches and low start & running current.
- Built-in overload with automatic reset.
- SJTOW severe duty oil and water resistant power cords, 20' length.
- ½ - 2 HP models have NEMA three prong grounding plugs.

AGENCY LISTINGS



Tested to UL 778 and CSA 22.2 108 Standards
By Canadian Standards Association
File #LR38549

MOTOR AND MODEL INFORMATION

Order Number	HP	Phase	Volts	RPM	Impeller Diameter (in.)	Maximum Amps	Locked Rotor Amps	KVA Code	Full Load Motor Efficiency %	Resistance Main (White - black)	Resistance Phase (white-brown)
VTX0511	0.5	1	115	3500	3.13	12.5	62.6	J	71	0.45 - 0.50	4.2 - 4.6
VTX0512			230			7.7	35.7	K	71	1.6 - 1.8	3.7 - 4.0
VTX1012	1		230		3.75	9.5	45.2	B	78	1.2 - 1.3	3.2 - 4.6
VTX1512	1.5		230		4.06	13.0		B	83	1.2 - 1.3	3.2 - 4.6
VTX2012	2		230		4.31	16.0		B	82	1.2 - 1.3	3.2 - 4.6

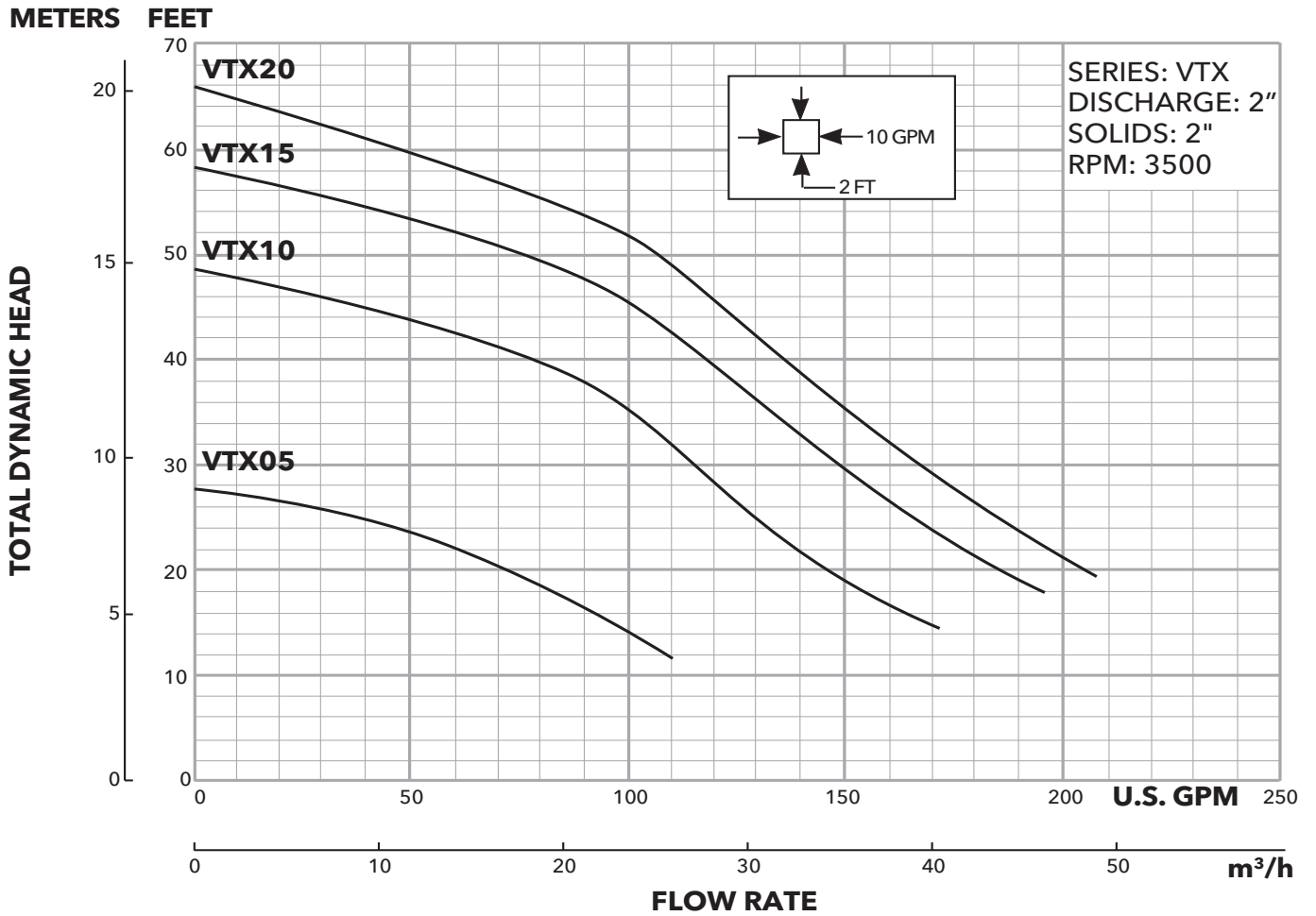

DIMENSIONS

(All dimensions are in inches.
Do not use for construction purposes.)

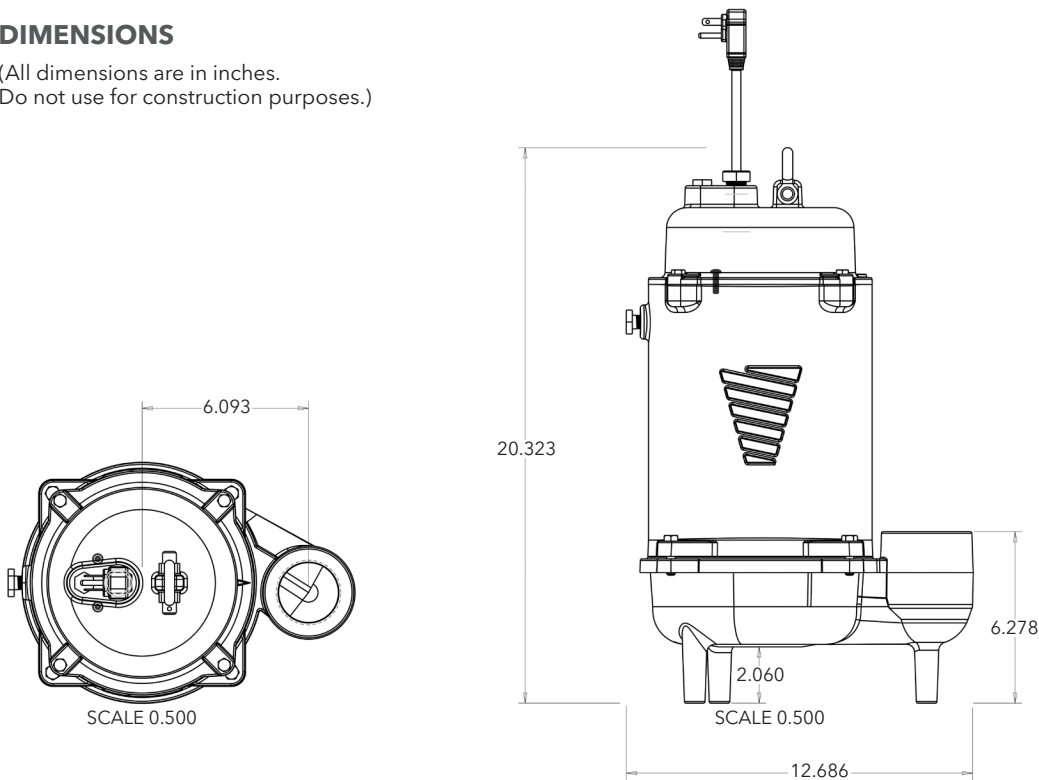

STANDARD PANEL OPTIONS

Pump Order Number	K-Series		Boulay Series	
	Simplex	Duplex	Simplex	Duplex
VTX0511	KS19020WF	KD19020WF	S10020	D10020
VTX0512	KS19020WF	KD19020WF	S10020	D10020
VTX1012	KS19020WF	KD19020WF	S10020	D10020
VTX1512	KS19020WF	KD19020WF	S10020	D10020
VTX2012	KS19020WF	KD19020WF	S10020	D10020

Note: Boulay Series part numbers have additional available features, see below for more information.

Note: K Series panel part numbers include floats, to order without float switches, remove the 'WF' suffix. Boulay Series panels do not include float switches.



K-SERIES

- NEMA 4X dead front outdoor rated enclosure
- Red LED alarm beacon
- HOA selector switch
- Field wiring terminal block
- Single phase models handle 120, 208 and 230V service
- Three phase models handle 200, 230 and 460V service
- Requires separate control/alarm power feed
- See brochure "BCPKSDPANELS" for additional information

BOULAY SERIES

- NEMA 4X outdoor rated enclosure
- Red alarm beacon
- HOA selector switch
- Through door pump run light(s)
- Through door alarm test and horn silence button
- Single phase models handle 120, 208 and 230V service
- Three phase models handle 200, 230, 460 and 575V service
- Accepts single or dual power feed
- See brochure "BCP3 R11" for additional information on simplex models
- See brochure "BCP4 R14" for additional information on duplex models



Xylem Inc.
2881 East Bayard Street Ext., Suite A
Seneca Falls, NY 13148
Phone: (866) 325-4210
Fax: (888) 322-5877
www.xylem.com/goulds

Goulds is a registered trademark of Goulds Pumps, Inc. and is used under license.
© 2019 Xylem Inc. BVTXSERIES R1 June 2019

Order Online: www.PumpCatalog.com